

**TALENT AND KNOWLEDGE MANAGEMENT ON EMPLOYEE PERFORMANCE IN
PUBLIC ORGANIZATION**

Hasmin Tamsah^A, Jumiatty Nurung^B, Nasriani^C, Yusriadi Yusriadi^D



ARTICLE INFO	ABSTRACT
<p>Article history:</p> <p>Received 31 January 2023</p> <p>Accepted 04 April 2023</p>	<p>Purpose: In the industrial era 4.0 and during this pandemic, the performance of community health centers (Puskesmas) is essential. Puskesmas can meet these expectations if it is properly built on health workers' performance.</p>
<p>Keywords:</p> <p>Talent Management; Knowledge Management; Performance; Public Organization.</p>	<p>Theoretical framework: This study aims to elaborate and analyze the model to improve health workers' performance, constructed as the impact of improving talent management and knowledge management.</p>
	<p>Design/methodology/approach: This research was conducted in two public health centers, namely Durikumba Health Center and Lara Health Center, Karossa District, and Central Mamuju Regency. The sampling technique used was total sampling. However, in this study, only 70 out of 74 health workers completed the questionnaire completely at the Durikumba Health Center and 45 out of 53 officers at the Lara Health Center. The total final sample obtained was 115 health workers. The model and research approach use explanatory quantitative by choosing structural equation modeling (SEM) as the basis for statistical analysis to determine the influence and relationship between variables processed using AMOS software.</p> <p>Findings: The study's results found that talent management can encourage knowledge management improvements and improve health workers' performance at the research sites.</p> <p>Research, Practical & Social implications: Talent management that is carried out consistently starting from recruitment, retaining existing talents, and with a good development program will encourage improvements in employee performance and, at the same time, improve knowledge management.</p> <p>Originality/value: However, knowledge management cannot improve the performance of health workers as constructed at the beginning of this study.</p> <p>Doi: https://doi.org/10.26668/businessreview/2023.v8i4.1557</p>

**A GESTÃO DO TALENTO E DO CONHECIMENTO NO DESEMPENHO DOS COLABORADORES
EM ORGANIZAÇÃO PÚBLICA**

RESUMO

Objetivo: Na era industrial 4.0 e durante esta pandemia, a atuação dos centros comunitários de saúde (Puskesmas) é fundamental. O Puskesmas pode atender a essas expectativas se for devidamente construído com base no desempenho dos profissionais de saúde.

^A Doctor in Economics, Sekolah Tinggi Ilmu Ekonomi AMKOP, Makassar, Indonesia.

E-mail: hasmintamsah40@gmail.com, Orcid: <https://orcid.org/0000-0002-9570-9658>

^B Doctor in Public Administration, Sekolah Pascasarjana Universitas Hasanuddin, Makassar, Indonesia.

E-mail: Correspondence: jumiattynurung469@gmail.com Orcid: <https://orcid.org/0000-0003-4366-8716>

^C Master in Management, Director of the Centre for Public Health Durikumba, Mamuju, Indonesia.

E-mail: nasrianinasriani680@gmail.com Orcid: <https://orcid.org/0009-0001-1683-5972>

^D Doctor in Public Administration, Sekolah Tinggi Ilmu Administrasi Puangrimaggalatung, Makassar, Indonesia.

E-mail: yusriadi.yusriadi@uqconnect.edu.au Orcid: <https://orcid.org/0000-0001-7908-1525>

Referencial teórico: Este estudo tem como objetivo elaborar e analisar o modelo para melhorar o desempenho dos trabalhadores da saúde, construído como o impacto da melhoria da gestão de talentos e da gestão do conhecimento.

Concepção/metodologia/abordagem: Esta pesquisa foi realizada em dois centros de saúde pública, nomeadamente Durikumba Health Center e Lara Health Center, Karossa District e Central Mamuju Regency. A técnica de amostragem utilizada foi a amostragem total. No entanto, neste estudo, apenas 70 dos 74 profissionais de saúde completaram o questionário no Centro de Saúde de Durikumba e 45 dos 53 funcionários do Centro de Saúde de Lara. A amostra final total obtida foi de 115 trabalhadores da saúde. O modelo e a abordagem de pesquisa usam o quantitativo explicativo, escolhendo a modelagem de equações estruturais (SEM) como base para a análise estatística para determinar a influência e a relação entre as variáveis processadas usando o software AMOS.

Resultados: Os resultados do estudo constataram que a gestão de talentos pode incentivar melhorias na gestão do conhecimento e melhorar o desempenho dos profissionais de saúde nos locais de pesquisa.

Implicações de pesquisa, práticas e sociais: A gestão de talentos realizada de forma consistente a partir do recrutamento, retendo os talentos existentes e com um bom programa de desenvolvimento, incentivará melhorias no desempenho dos funcionários e, ao mesmo tempo, melhorará a gestão do conhecimento.

Originalidade/valor: No entanto, a gestão do conhecimento não pode melhorar o desempenho dos profissionais de saúde conforme construído no início deste estudo.

Palavras-chave: Gestão de Talentos, Gestão do Conhecimento, Desempenho, Organização Pública.

GESTIÓN DEL TALENTO Y EL CONOCIMIENTO SOBRE EL DESEMPEÑO DE LOS EMPLEADOS EN LAS ORGANIZACIONES PÚBLICAS

RESUMEN

Propósito: En la era industrial 4.0 y durante esta pandemia, la actuación de los centros de salud comunitarios (Puskesmas) es fundamental. Puskesmas puede cumplir con estas expectativas si se basa adecuadamente en el desempeño de los trabajadores de la salud.

Marco teórico: Este estudio tiene como objetivo elaborar y analizar el modelo para mejorar el desempeño de los trabajadores de la salud, construido como el impacto de mejorar la gestión del talento y la gestión del conocimiento.

Diseño/metodología/enfoque: Esta investigación se llevó a cabo en dos centros de salud pública, a saber, el Centro de Salud Durikumba y el Centro de Salud Lara, Distrito de Karossa y Regencia Central de Mamuju. La técnica de muestreo utilizada fue el muestreo total. Sin embargo, en este estudio, solo 70 de 74 trabajadores de salud completaron el cuestionario completamente en el Centro de Salud de Durikumba y 45 de 53 funcionarios en el Centro de Salud de Lara. La muestra final total obtenida fue de 115 trabajadores de la salud. El modelo y el enfoque de investigación utilizan la explicación cuantitativa al elegir el modelo de ecuaciones estructurales (SEM) como base para el análisis estadístico para determinar la influencia y la relación entre las variables procesadas utilizando el software AMOS.

Hallazgos: Los resultados del estudio encontraron que la gestión del talento puede fomentar mejoras en la gestión del conocimiento y mejorar el desempeño de los trabajadores de la salud en los sitios de investigación.

Implicaciones de investigación, prácticas y sociales: la gestión del talento que se lleva a cabo de manera consistente desde el reclutamiento, reteniendo los talentos existentes y con un buen programa de desarrollo fomentará mejoras en el desempeño de los empleados y, al mismo tiempo, mejorará la gestión del conocimiento.

Originalidad/valor: Sin embargo, la gestión del conocimiento no puede mejorar el desempeño de los trabajadores de la salud como se construyó al inicio de este estudio.

Palabras clave: Gestión del Talento, Gestión del Conocimiento, Desempeño, Organización Pública.

INTRODUCTION

Public organizations have a very important role in providing services to the community. Excellent service can be implemented if it is supported by maximum employee performance. In Indonesia, especially in districts/cities in supporting the implementation of public services, especially in health services to the community, the presence of community health centers

(puskesmas) is very meaningful. Puskesmas is a functional organization that organizes health efforts that are comprehensive, integrated, equitable, acceptable, and affordable to the community.

Puskesmas, as a service industry provides services, has developed rapidly, resulting in many obstacles. During the current crisis, many parties are aware of the demand for the ability to work for health workers. The ability to work with health workers is very important in carrying out the goals of the Puskesmas. An integrated talent management system that is integrated and in harmony with knowledge management can improve employee performance (Nisa et al., 2016). The performance will achieve maximum results if it is supported by knowledge. Every employee is expected to continue to explore their knowledge and not just depend on or fixate on the existing system.

Knowledge management is used to improve communication between top management and employees to improve work processes, instill a culture of knowledge sharing, and promote and implement performance-based reward systems (Gold et al., 2001). Knowledge has become very decisive; therefore, its acquisition and utilization need to be managed properly to improve employee performance (Nisa et al., 2016).

Talent management is one of the most decisive factors in building and improving employee abilities. The talent management application will provide direction for improvement that can facilitate knowledge management to improve employee and organizational performance. The author wants to give a clear picture of this flow, although within the limitations of supporting references, especially the relationship between talent management and knowledge management. The problem is that there is still very little research in the public sector. Various studies on the relationship between talent management and performance (Bibi, 2019; Linah Mahlahla, 2018; Payambarpour & Hooi, 2015; Vural et al., 2012), then knowledge management and execution (Adriaenssen et al., 2016; Ahmad et al., 2018; Alyoubi et al., 2018; Khanal & Raj Poudel, 2017; Paulin & Suneson, 2011; Valmohammadi et al., 2019), but it is still sporadic to write in the public sector, especially in the health sector.

The author tries to provide an overview of talent management and knowledge management in public organizations and their impact on improving the performance of health workers. This research was built by relying on human capital theory. The author sees the potential for human resources in the form of talents and knowledge (Bontis, 2004; Sharabati et al., 2010) owned by every employee in public organizations that can be utilized to improve their performance which in turn can improve organizational performance.

LITERATURE REVIEW

Companies use various talent management methods to find, train, retain and place the right people in the right jobs. Talent management is a strategy for managing talent efficiently within an organization, preparing and encouraging success in business, maximizing employee self-development, and making the best use of talent (Capelli, 2008). Furthermore, (Pella et al., 2011) stated that talent management is a procedure to ensure companies fill important positions for future leaders and jobs that complement the organization's core capabilities, such as unique skills and high strategic value. Talent management has a beneficial and significant impact on improving employee performance (Kosasih et al., 2007; Praharsi & Yugowati, 2016; Sukoco & Fadillah, 2016; Wijayanti & Sundiman, 2017). In achieving the goals for corporate sustainability, employee performance is an essential aspect. Several variables can affect performance, including internal and external variables. Individual elements, such as knowledge and qualities that people are born with, impact employee performance (Titin et al., 2022).

Talent management is a relatively new study, especially in public organizations. Nevertheless, the efforts made in recruiting, retaining, and developing the potential of the talents possessed (D.E.M. Sleiderink, 2012) are significant in the organization. As measured by recruitment, retention, and development, talent management can improve customer satisfaction, and knowledge management has strengthened these relationships (Al-Azzam & Al-Qura'an, 2019). Talent management carried out in a structured and tiered manner will improve employee performance (Bibi, 2019; Linah Mahlahla, 2018; Payambarpour & Hooi, 2015; Vural et al., 2012).

Several studies on talent management, among others, suggest that talent management has not yet been clear about the scope, definition, and overall goals of talent management (Lewis & Heckman, 2006). However, recent studies have shown that nursing practitioners use a multiphase talent management system consisting of six successive phases and associated success factors that promote effective implementation (Groves, 2011). Furthermore, it can also improve organizational performance besides improving individual performance (Auntie, 2019; Kadyrbekova, 2017; Masri & Suliman, 2019) (Hongal & Kinange, 2020; Payambarpour & Hooi, 2015).

Talent management can also contribute to the development of knowledge management (Whelan & Carcary, 2011). Talent management that is carried out in a planned manner will improve knowledge management which can further improve employee performance (Bani-Hani, 2021). The recruitment process by prioritizing development considerations will make it

easier for organizations to manage knowledge. A good recruitment pattern will also make it easier for the organization to retain the talents needed (Kiran et al., 2022). Furthermore, continuous and regular employee development will make it easier for organizations to manage employee abilities and knowledge (Hussinki et al., 2017; Khaksar et al., 2011; Whelan & Carcary, 2012).

Knowledge management refers to how an organization handles knowledge at various stages of its life. There are four measures of knowledge management: knowledge discovery, knowledge capture, knowledge sharing, and knowledge application (Becerra et al., 2010). By prioritizing knowledge management, it is easier to achieve individual employee performance (Adriaenssen et al., 2016; Ahmad et al., 2018; Alyoubi et al., 2018; Khanal & Raj Poudel, 2017; Paulin & Suneson, 2011; Valmohammadi et al., 2019) and also organizational performance (Al-Abadi et al., 2020). Based on these relationships, the following hypotheses can be formulated:

H1: Talent management has a positive and significant effect on the performance of health workers.

H2: Talent management has a significant positive effect on the knowledge management of health workers.

H2: Knowledge management has a positive and significant effect on the performance of health workers.

MATERIAL AND METHODOLOGY

Sample Criteria

The sample in this study was 115 people who were health workers, with 17 males (14.78%) and 98 females (85.22%). Where as many as three male doctors (2.61%) and three people (2.61%) women, nurses as many as eight people (6.96%) male and 13 people (11.30%) female, there are no males and 63 (54.78%) female midwives, 2 (1.74%) male, and one female (0.87%) environmental health workers, no male medical laboratory experts -men and 2 (1.74%) women. There were no male pharmacists, and 8 (6.96%) women, 2 (1.74%) male public health workers and 5 (4.35%) were female, there were no male nutritionists and 3 (2.61%) female, and 2 (1.74%) male ambulance drivers and no female. The dominant respondents are in the age range between 26 - 30 years, namely 47.8%. The rest are in the age range between 31 and over, as much as 47.7%, and 20 - 25 years, as much as 4.3%. In terms of education, the highest completed

their Diploma as much as 53.92%, undergraduate 44.35%, and the remaining 1.73% are at the high school level or equivalent.

Measurement

The model and research approach use explanatory quantitative by choosing structural equation modelling (SEM) as the basis for statistical analysis to determine the influence and relationship between variables processed using AMOS software. Then data collection using a survey with a Likert scale (1 = strongly disagree, 2 = disagree, 3 = neutral, 4 = agree, 5 = strongly agree). This research was conducted in 2 (two) health centres, namely Durikumba Health Centre and Lara Health Centre in Central Mamuju Regency. The sampling technique in this study used the total sampling method, which consisted of 74 officers at the Durikumba Health Centre and 53 officers at the Lara Health Centre, so the total sample was 127.

The conceptual framework is illustrated in Figure 1 with Talent Management (TM) as an exogenous variable, Knowledge Management (KM) as a mediator variable, and Employee Performance (EP) as an endogenous variable. The dependent and independent variables are three (e.g., talent management, knowledge management, and employee performance). The talent Management (TM) variable refers to the study of, e.g. (Capelli 2008), three leading indicators, e.g., recruitment (TM1); retain (TM2); and development (TM3). Knowledge Management (KM) variable refers to the study, e.g. (Becerra et al., 2010), with four indicators, e.g., knowledge discovery (KM1); knowledge capture (KM2); knowledge sharing (KM3); and knowledge application (KM4). Employee Performance (EP) variable refers to the study, e.g. (Dessler, 2006; Tamsah et al., 2020), which consists of five indicators, e.g., quality (EP1); productivity (EP2); trust (EP3); availability (EP4); and freedom (EP5).

There are two stages in testing parametric statistics, especially using AMOS, namely: the first step is to extract the distribution of the questionnaire in the form of a Likert scale included in the SPSS application, then test the normality of the data using the Kolmogorov-Smirnov residual method with the criteria (Asymp. Sig > 0.05). In the first stage of testing, the normality value of $0.20 > 0.05$ was obtained to conclude that it was normally distributed. Furthermore, validity testing was carried out using the spearman-correlation method and the reliability value with SPSS. The test results were valid at the 0.01 level range and reliable above 0.60 (Ferdinand, 2006, 2014). The second step is to export data from SPSS to AMOS to determine the estimated common value, standard error (SE), and critical ratio (CR). In addition, it is still in the classical assumption testing step in AMOS, the Goodness fit of Model (GoF) criteria by looking at the

expected Chi-Square value is small; RMSEA < 0.08; GFI > 0.90; AGFI > 0.90; Degree of Freedom > 2.0; CFI and TLI > 0.95.

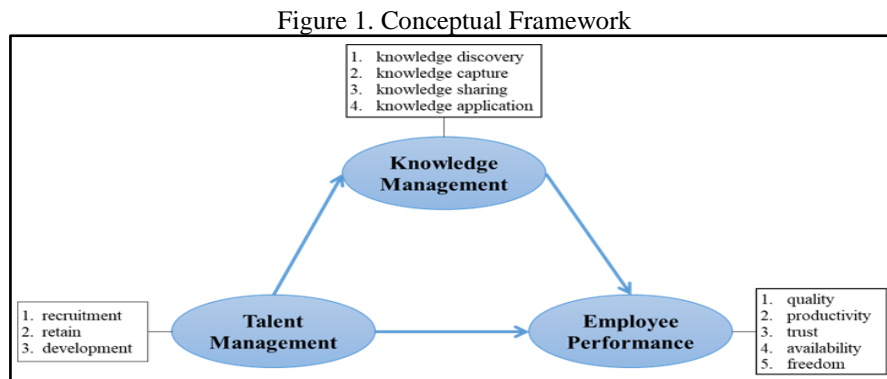

Source: Prepared by the authors (2022)

RESULTS

The statistical test results in Table 1 show that the overall P-value of the variables and items is significant < 0.05. The value of critical ratio items on average is above 1.89; the standard error value (S.E) is also minimal compared to the estimated value. Meanwhile, standardized estimates for indicators of variables, in general, are above 0.60 (Ferdinand, 2014; Hair et al., 2014; Hall, 2001), which can be interpreted that the indicator intervention on the standardized estimate value is in a high range. However, there are still indicators of variables in the field of 0.4 - 0.60, where which is considered to be in a low category. Furthermore, several indicators are removed from the test, such as the availability (EP4) and freedom (EP5) indicators for the Employee Performance (EP) variable. The deleted arrows indicate that the validity values and standard estimates are not met as well as for model improvement.

The dominant indicator component forming the Talent Management (TM) variable is the development indicator (TM3), with an expected estimate value of 0.694. Furthermore, the dominant Knowledge Management (KM) variable is formed by the knowledge sharing indicator (KM3) with a standard estimate value of 0.771. The dominant Employee Performance (EP) variable is created by the productivity indicator (EP2) with a normal estimate value of 0.784.

Table 1: Statistical Result

Variables	Item	Standardized Estimate	Estimate	Standard Error (S.E)	Critical Ratio (CR)	P-Value
Talent Management (TM)	recruitment	0,694	0,505	0,157	3,211	0,001
	retain	0,502	0,617	0,165	3,744	***

	development	0,694	1,000	-	-	-
Knowledge Management (KM)	knowledge discovery	0,622	0,717	0,144	4,979	***
	knowledge capture	0,487	0,650	0,155	4,191	***
	knowledge sharing	0,771	1,000	-	-	-
	knowledge application	0,488	0,783	0,186	4,200	***
Employee Performance (EP)	quality	0,701	1,295	0,298	4,340	***
	productivity	0,784	1,665	0,379	4,388	***
	trust	0,490	1,000	-	-	-
	availability	deleted item	-	-	-	-
	freedom	deleted item	-	-	-	-
Knowledge Management ← Talent Management		0,529	0,602	0,195	3,089	0,002
Employee Performance ← Talent Management		0,613	0,430	0,172	2,505	0,012
Employee Performance ← Knowledge Management		0,151	0,093	0,103	0,902	0,367
Model Fit Testing		Value			Info	
Normality Test (Kolmogorov-Smirnov Test)		0.12 > 0.05			Normal / Parametric	
Chi-Square		48,701			Ideal	
Degree of Freedom		32			Ideal	
CMIN		1.522			Fit	
GFI		0.925 > 0.90			Fit	
AGFI		0.871 > 0.80			Fit	
TLI		0.889 < 0.90			Ideal	
CFI		0.921 > 0.90			Fit	
RMSEA		0.068 > 0.08			Fit	

Note: *** (Significant at Level P < 0.01)

Source: Prepared by the authors (2022)

The study's results, as shown in Table 1, show that the feasibility test of the model has met the requirements of Structural Equation Modeling. As in the normality test, which states the Kolmogorov-Smirnov method, Asymp. Sig = 0.20 > 0.05, so it is noted that the normality assumption has been met and has typically distributed data. Furthermore, the Goodness of Fit model through Chi-Square, DF, GFI, TLI, AGFI, and RMSEA values also shows ideal bargains, and most of the model's eligibility requirements are declared Fit (qualified). These results can also be seen in the structural model, as shown in Figure 2.

Figure 2. Structural Equation Model

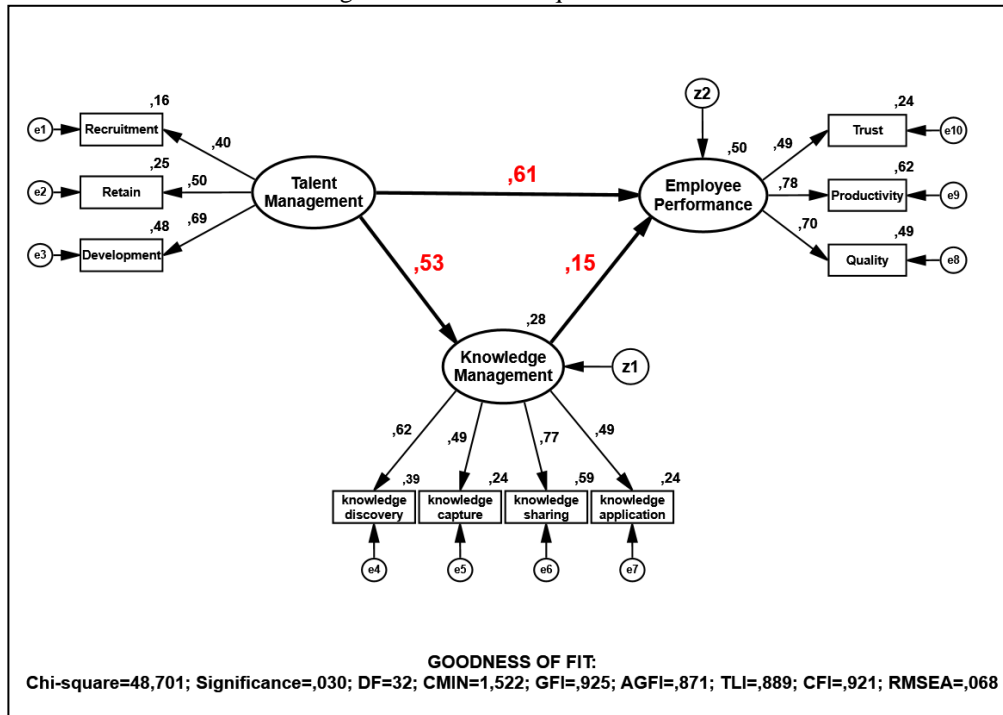

Source: Prepared by the authors (2022)

After the first and second stages of testing were carried out, the last stage was hypothesis testing through an effect test by comparing the T-statistical value to the P-Value weight (significant coefficient <0.05).

Table 2: Regression Result

Hypothesis	Estimate	C.R	p-Value	Info
Talent Management (TM) → Knowledge Management (KM)	0,529	3,089	0.002 < 0.05	Support
Talent Management (TM) → Employee Performance (EP)	0,613	2,505	0.012 < 0.05	Support
Konowledge Management (KM) → Employee Performance (EP)	0,151	0,902	0.367 > 0.05	Not Support

Source: Prepared by the authors (2022)

The hypothesis testing described in Table 2 shows the relationship between the variables Talent Management (TM) on Knowledge Management (KM) and Talent Management (TM) on Employee Performance (EP). And Knowledge Management (KM) on Employee Performance (EP) can see that Hypothesis H1 – H2 has a positive and significant effect with a significance value of <0.05. While the third hypothesis is the relationship between the variables Knowledge Management (KM) on Employee Performance (EP) does not have a significant effect (C.R = 0.902, Sig = 0.367 > 0.05).

DISCUSSION

Talent management is a process to ensure a company fills key positions of future leaders and positions that support unique skills and high strategic value (Pella et al., 2011). The results showed that talent management contributed greatly to performance improvement, which was 0.613. This result is in line with (Nur et al., 2017; Octavia & Susilo, 2018), where talent management strongly influences employee performance improvement. In this study, to improve talent management as measured by recruitment, retention, and development, the development indicator has a large contribution of 0.69, then retain 0.50, and recruitment is 0.40.

Talent management can also improve knowledge management by 0.529. Thus, talent management can be a comprehensive strategic approach to identifying, evaluating, developing, and allocating talented or talented human resources to facilitate the management of knowledge possessed by employees. Such talent management can also help the activities of achieving the best performance of the organization. This study also shows that knowledge sharing is the most dominant form of forming knowledge management. Knowledge sharing in the context of knowledge management and all indicators forming knowledge management can encourage the performance of health workers (Cahaya et al., 2022; Yusriadi & Cahaya, 2022). However, this is not as good as the impact caused by talent management.

The influence of the knowledge management variable on employee performance is positive and significant. Knowledge management in this study is built from the knowledge discovery indicator (0.62), knowledge capture (0.49); knowledge sharing (0.77); and knowledge application (0.49). Of the four indicators that mark knowledge management, the most significant contribution is knowledge sharing. The lowest is knowledge capture and application, as knowledge is known as a structured experience, values, and contextual information (Nurman et al., 2022; Yusriadi, Awaluddin, et al., 2022; Yusriadi, Makkulawu Panyiw Kessi, et al., 2022). And the expert insight provides a framework for evaluating and combining new experiences and knowledge that results in action and better decisions and produces effective inputs for dialogue and organizational creativity (Gold et al. ., 2001).

The findings show that talent management affects improving employee performance which focuses on how to develop strategies and assessments. Talent management includes selecting and developing employees who are considered talented in the company so that it can produce a group of people whose talents can be developed to become an investment in it (Lewis & Heckman, 2006). With standardized recruitment, retaining existing talents, and developing capabilities through knowledge management, employees will reach the peak of their abilities to

encourage performance improvement (Idris et al., 2022; Ilyas et al., 2022; Kasim et al., 2022; Tamsan & Yusriadi, 2022). Effective use of knowledge will create a competitive advantage and improve good performance within the organization (Zaied, 2012). It is necessary to manage their expertise through knowledge management to get the maximum benefit from the knowledge possessed and know the knowledge that must be included.

CONCLUSIONS

Based on the results of research and discussion, it can be concluded that talent management can improve knowledge management and employee performance simultaneously. So, if talent management is carried out properly, it will produce employees who perform well and, on the other hand, can improve knowledge management properly. However, although knowledge management increases because of improved talent management, it does not contribute to improving employee performance (Hussin & Aziz, 2021). Knowledge management also cannot be an intermediary that can improve the contribution of talent management to improving employee performance in public organizations. Thus, if you try to recruit, retain, and develop employees you have directly, you can encourage improvement in employee performance in public organizations (Ismail, 2022). Performance improvements due to improved talent management are more practical than improvements resulting from employee knowledge management. Improvements in talent management were obtained from the largest contribution from development indicators and the smallest from good recruitment.

Furthermore, knowledge management can be improved with the largest contribution of knowledge discovery indicators, the smallest being knowledge capture and application. Meanwhile, performance improvement can only be seen in productivity, quality, and trust. These results provide managerial contributions to the development of human capital theory and become empirical evidence of the relationship between talent management and knowledge management, lacking so far.

REFERENCES

- Adriaenssen, D. J., Johannessen, D. A., & Johannessen, J. A. (2016). Knowledge management and performance: Developing a theoretical approach to knowledge workers' productivity, and practical tools for managers. *Problems and Perspectives in Management*, 14(3), 667–676. [https://doi.org/10.21511/ppm.14\(3-3\).2016.10](https://doi.org/10.21511/ppm.14(3-3).2016.10)
- Ahmad, J., Malik, M. I., & Anwar, A. (2018). Knowledge management and employee's performance in telecommunication industry. *FWU Journal of Social Sciences*, 12(2), 135–146.

- Al-Abbadi, L., Alshawabkeh, R., & Rumman, A. A. (2020). Knowledge management processes and innovation performance: The moderating effect of employees' knowledge hoarding. *Management Science Letters*, 10(7), 1463–1472. <https://doi.org/10.5267/j.msl.2019.12.021>
- Al-Azzam, Z., & Al-Qura'an, A. (2019). How Knowledge Management Mediates the Strategic Role of Talent Management in Enhancing Customers' Satisfaction. *SSRN Electronic Journal*, February. <https://doi.org/10.2139/ssrn.3364693>
- Alyoubi, B., Hoque, M. R., Alharbi, I., Alyoubi, A., & Almazmomi, N. (2018). Impact of Knowledge Management on Employee Work Performance: Evidence from Saudi Arabia. *The International Technology Management Review*, 7(1), 13. <https://doi.org/10.2991/itmr.7.1.2>
- Bani-Hani, J. S. (2021). The moderating influence of managers strategic thinking on the effect of talent management on organization core competency. *Management Science Letters*, 11(1), 213–222. <https://doi.org/10.5267/j.msl.2020.8.013>
- Becerra, I. F., & Sabherwal. (2010). *Knowledge Management: Systems and Processes*. USA: M.E Sharpe.
- Bibi, M. (2019). Impact of talent management practices on employee performance: an empirical study among healthcare employees. *SEISENSE Journal of Management*, 2(1), 22–32.
- Bontis, N. (2004). National Intellectual Capital Index: A United Nations initiative for the Arab region. In *Journal of Intellectual Capital* (Vol. 5, Issue 1). <https://doi.org/10.1108/14691930410512905>
- Cahaya, A., Yusriadi, Y., & Gheisari, A. (2022). Transformation of the Education Sector during the COVID-19 Pandemic in Indonesia. *Education Research International*, 2022. <https://doi.org/10.1155/2022/8561759>
- Capelli, P. (2008). *Talent on Demand*. United States of America: Harvard Business School Publishing.
- D.E.M. Sleiderink. (2012). Talent management in health care: Identifying and retaining talent at Medisch Spectrum Twente [University of Twente]. In *School of Management and Governance* (Vol. 14, Issue 4). [https://doi.org/10.1016/0260-6917\(94\)90152-x](https://doi.org/10.1016/0260-6917(94)90152-x)
- Dessler, G. (2006). *Manajemen Sumber Daya Manusia Edisi Kesepuluh Jilid 1 (terj.)*. 1, 2006.
- Ferdinand, A. (2006). Metode Penelitian Manajemen Pedoman Penelitian untuk Penulisan Skripsi Tesis dan disertai Ilmu Manajemen. In *Semarang: Universitas Diponegoro*.
- Ferdinand, A. (2014). *Structural Equation Modelling: dalam Penelitian Manajemen, Aplikasi Model-Model Rumit dalam Penelitian untuk Skripsi, Tesis, dan Disertasi Doktor* (5th ed.). BP Undip - Undip Press.
- Gold, A. H., Malhotra, A., & Segars, A. H. (2001). Knowledge management: An organizational capabilities perspective. *Journal of Management Information Systems*. <https://doi.org/10.1080/07421222.2001.11045669>
- Groves, K. S. (2011). Talent management best practices: How exemplary health care organizations create value in a down economy. *Health Care Management Review*, 36(3), 227–

240.

Hair, J. F., Patel, M. L., K., D. S. G. V., Gabriel, M. L. D. da S., Patel, V. K., Patel, M. L., & K., D. S. G. V. (2014). Amos Covariance-Based Structural Equation Modeling (CB-SEM): Guidelines On Its Application as a Marketing Research Tool. *Brazilian Journal of Marketing - BJM Revista Brasileira de Marketing – ReMark Edição Especial*, 13(2), 44–55. <https://doi.org/10.5585/remark.v13i2.2718>

Kiran, V. S., Shanmugam, V., Raju, R. K., & Kanagasabapathy, J. R. (2022). Impact of Human Capital Management on Organizational Performance With the Mediation Effect of Human Resource Analytics. *International Journal of Professional Business Review*, 7(3), e0667–e0667.

Hall, P. (2001). Statistical Science. In *Mathematics Unlimited — 2001 and Beyond*. https://doi.org/10.1007/978-3-642-56478-9_28

Hongal, P., & Kinange, D. U. (2020). A Study on Talent Management and its Impact on Organization Performance- An Empirical Review. *International Journal of Engineering and Management Research*, 10(01), 64–71. <https://doi.org/10.31033/ijemr.10.1.12>

Hussinki, H., Ritala, P., Vanhala, M., & Kianto, A. (2017). Intellectual capital, knowledge management practices and firm performance. *Journal of Intellectual Capital*, 18(4), 904–922. <https://doi.org/10.1108/JIC-11-2016-0116>

Idris, M., bin Tahir, S. Z., Wilya, E., Yusriadi, Y., & Sarabani, L. (2022). Availability and Accessibility of Islamic Religious Education Elementary School Students in Non-Muslim Base Areas, North Minahasa, Indonesia. *Education Research International*, 2022. <https://doi.org/10.1155/2022/6014952>

Ilyas, G. B., Rahmi, S., Tamsah, H., & Yusriadi, Y. (2022). Does fear of missing out give satisfaction in purchasing based on social media content? *International Journal of Data and Network Science*, 6(2), 409–418. <https://doi.org/10.5267/j.ijdns.2021.12.013>

Kadyrbekova, U. A. (2017). Prospects for the use of the concept and methods of talent management in the practice of public service (on the materials of the Republic of Kazakhstan) Perspectivas para el uso del concepto y métodos de gestión del talento en la práctica del servicio púb. *Revista Espacios*, 38(48), 19–26.

Kasim, A., Nawas, K. A., Tahir, S. Z. B., Yusriadi, Y., & Gheisari, A. (2022). Bugis and Arabic Morphology: A Contrastive Analysis. *Education Research International*, 2022. <https://doi.org/10.1155/2022/9031458>

Khaksar, S. M. S., Yaghoobi, N. M., Jahanshahi, A. A., Nawaser, K., Mohammad, S., Khaksar, S. M. S., Nawaser, K., & Afshar, A. (2011). The study of training impact on knowledge management and organizational performance. *Journal of Applied Sciences Research*, 7(7), 1069–1080.

Khanal, L., & Raj Poudel, S. (2017). Saudi Journal of Business and Management Studies Knowledge Management, Employee Satisfaction and Performance: Empirical Evidence from Nepal. *Saudi Journal of Business and Management Studies*, 2(2), 82–91. <https://doi.org/10.21276/sjbms.2017.2.2.3>

Kosasih, Natalia, Budiani, & Sri. (2007). Pengaruh Knowledge Management terhadap Kinerja Karyawan: Studi Kasus Departemen Front Office Surabaya Plaza Hotel. *Jurnal Manajemen Perhotelan*, 2007.

Lewis, R. E., & Heckman, R. J. (2006). Talent management: A critical review. *Human Resource Management Review*, 16(2), 139–154. <https://doi.org/10.1016/j.hrmr.2006.03.001>

Linah Mahlahla. (2018). *The Impact of Talent Management on Employee Performance and Retention Strategies: A Case Study of Masvingo City Council in Zimbabwe* (Issue April). Durban University of Technology.

Masri, N. El, & Suliman, A. (2019). Talent Management, Employee Recognition and Performance in the Research Institutions. *Studies in Business and Economics*, 14(1), 127–140. <https://doi.org/10.2478/sbe-2019-0010>

Mijbil Dway Ismail. (2022). The quality of the auditor's report considering the negative aspects of creative accounting methods and procedures. *International Journal of Professional Business Review*, 7(4), e0656. <https://doi.org/10.26668/businessreview/2022.v7i4.e656>

Nik Hussin, N. S., & Aziz, Z. A. (2021). Socioeconomic Development on Poverty Alleviation of Women Entrepreneurship. *International Journal of Professional Business Review*, 6(1), e0283. <https://doi.org/10.26668/businessreview/2021.v6i1.283>

Nisa, R. C., Astuti, E. S., & Prasetya, A. (2016). Pengaruh Manajemen Talenta dan Manajemen Pengetahuan Terhadap Kinerja Karyawan (Studi pada Karyawan PT. PLN (Persero) Distribusi Jawa Timur, Surabaya). *Jurnal Administrasi Bisnis*, 32(2), 141–148.

Nur, R. N. N., Fauzi, A. M., & Sukoco, H. (2017). Strategies of Knowledge Management Implementation for Academic Services Improvement of Indonesian Higher Education. *Journal of Information and Knowledge Management*, 16(4), 1–23. <https://doi.org/10.1142/S0219649217500320>

Nurman, Yusriadi, Y., & Hamim, S. (2022). Development of Pluralism Education in Indonesia: A Qualitative Study. *Journal of Ethnic and Cultural Studies*, 9(3), 106–120. <https://doi.org/10.29333/ejecs/1207>

Octavia, H. V., & Susilo, H. (2018). Pengaruh Manajemen Talenta terhadap Kinerja Karyawan (Studi Pada Karyawan PT Pertamina Geothermal Energy Area Ulubelu). *Jurnal Administrasi Bisnis (JAB)*, 60(2018), 186.

Paulin, D., & Suneson, K. (2011). Knowledge transfer, knowledge sharing and knowledge barriers-three blurry terms in KM. *Proceedings of the European Conference on Knowledge Management, ECKM*, 2(1), 752–760.

Payambarpour, S. A., & Hooi, L. W. (2015). The impact of talent management and employee engagement on organisational performance. *International Journal of Management Practice*, 8(4), 311–336. <https://doi.org/10.1504/IJMP.2015.073483>

Pella, Ahmad, D., & Inayati, A. (2011). *Talent Management Mengembangkan SDM untuk Mencapai Pertumbuhan dan Kinerja Prima*. Jakarta: PT.Gramedia.

- Praharsi, & Yugowati. (2016). Manajemen Pengetahuan dan Implementasinya dalam Organisasi dan Perorangan. *Jurnal Manajemen Maranatha*, 16(1), 2016.
- Sharabati, A. A., Jawad, S. N., & Bontis, N. (2010). *Intellectual capital and business performance in the pharmaceutical sector of Jordan*. 48(1), 105–131. <https://doi.org/10.1108/00251741011014481>
- Sukoco, I., & Fadillah, A. R. (2016). Analisis Strategi Manajemen Talenta Menggunakan Pendekatan Kompetensi Organisasional pada PT. Pindad (Persero) Bandung. *Jurnal AdBispreneur*, 1(1), 2016.
- Tamsah, H., Ansar, Ilyas, G. B., & Yusriadi, Y. (2020). Training, Knowledge Sharing, and Quality of Work-Life on Civil Servants Performance in Indonesia. *Journal of Ethnic and Cultural Studies*, 7(3), 163–176. <https://doi.org/http://dx.doi.org/10.29333/ejecs/514>
- Tamsan, H., & Yusriadi, Y. (2022). Quality of agricultural extension on productivity of farmers: Human capital perspective. *Uncertain Supply Chain Management*, 10(2), 625–636. <https://doi.org/10.5267/j.uscm.2021.11.003>
- Titin, M. M., Budiyanto, B., & Suhermin, S. (2022). The Effect of Leadership Capability and Collective Commitment With Personal Value Mediation on Cooperative Performance in Lamongan District. *International Journal of Professional Business Review: Int. J. Prof. Bus. Rev.*, 7(3), 4.
- Valmohammadi, C., Sofiyabadi, J., & Kolahi, B. (2019). How do knowledge management practices affect sustainable balanced performance? Mediating role of innovation practices. *Sustainability (Switzerland)*, 11(18). <https://doi.org/10.3390/su11185129>
- Vural, Y., Vardarlier, P., & Aykir, A. (2012). The Effects of Using Talent Management With Performance Evaluation System Over Employee Commitment. *Procedia - Social and Behavioral Sciences*, 58, 340–349. <https://doi.org/10.1016/j.sbspro.2012.09.1009>
- Whelan, E., & Carcary, M. (2011). Integrating talent and knowledge management: Where are the benefits? *Journal of Knowledge Management*, 15(4), 675–687. <https://doi.org/10.1108/13673271111152018>
- Whelan, E., & Carcary, M. (2012). Integrating a Talent Management Approach to Knowledge Management: Are There Benefits to Be Had? *SSRN Electronic Journal*. <https://doi.org/10.2139/ssrn.1694455>
- Wijayanti, D. P., & Sundiman, D. (2017). Pengaruh Knowledge Management terhadap Kinerja Karyawan: Studi Empiris pada PT. SMS Kabupaten Kotawaringin Timur. *DeReMa Jurnal Manajemen*, 12. <https://doi.org/http://dx.doi.org/10.19166/derema.v12i1.243>
- Yusriadi, Y., Awaluddin, M., Firman, H., & Asrijal, A. (2022). Implementation of e-commerce in supply chain management. *Uncertain Supply Chain Management*, 10(4), 1279–1288. <https://doi.org/10.5267/j.uscm.2022.7.012>
- Yusriadi, Y., & Cahaya, A. (2022). Food security systems in rural communities: A qualitative study. *Frontiers in Sustainable Food Systems*, 6. <https://doi.org/10.3389/fsufs.2022.987853>

Yusriadi, Y., Makkulawu Panyiwi Kessi, A., Awaluddin, M., & Sarabani, L. (2022). E-Learning-Based Education Resilience in Indonesia. *Education Research International*, 2022. <https://doi.org/10.1155/2022/7774702>

Zaied, A. N. H. (2012). An Integrated Success Model for Evaluating Information System in Public Sectors. *Journal of Emerging Trends in Computing and Information Sciences*, 3(6), 814–825. <http://www.doaj.org/doaj?func=fulltext&aId=1093381>